



# YEAR 2 D.T: MECHANISMS – WHEELS AND AXLES

## KNOWLEDGE ORGANISER



### Overview

#### Wheels and Axles

Mechanisms are the parts that make something work.

-Mechanisms are all around us! Most objects that help us in our lives are made up of different mechanisms.

Wheels and Axles are mechanisms that help things to move.

-Wheels are circular objects that roll on the ground, helping vehicles and other objects to easily move.

-Axles are rods that help wheels to rotate. The wheel can either rotate freely on the axle, or be attached to (and turn with) the axle.



### Example Mechanisms



Ferris Wheel

-A Ferris Wheel is one example of a wheel and axle mechanism in action. Normally, Ferris Wheels are fixed to the axle. Force is applied to the axle which makes it spin. This makes the giant wheel spin too!



Roller Skates

-Roller skates are another example of wheel and axle mechanisms. Obviously, there are four wheels here instead of one, and the wheels are much smaller. Often, the wheels rotate free from the axle, but sometimes they are fixed.



Toy Car

Toy cars (and real cars) use wheel and axle mechanisms to move. On toy cars, the wheel is normally fixed to the axle, meaning both the wheel and axle spin. This makes it really important that there is not too much friction on the axle, or the wheel will not move!

### Designing

-You need to think about who your product is for – what is its purpose and who is going to use it?

#### Chassis

-The chassis is the frame or base on which the vehicle is built. A chassis should be strong and rigid enough to hold the vehicle.

-The chassis should include axle holders. These designed so that the axles do not have too much friction against them.

#### Axle

-Consider what you will make your axle from. It needs to be strong enough to hold the wheels, and fit freely in the axle holder.

#### Wheel

-Consider whether your wheels will be fixed to the axle, or free.

-If fixed, they need to be firmly attached. If not, they need a stopper to prevent them from falling off.

-Some materials allow the wheel to move more freely on surfaces.

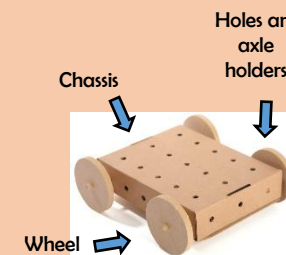

### Key Vocabulary

- Mechanism
- Wheel
- Axis
- Axle Holder
- Friction
- Dowel
- Chassis
- Design
- Make
- Evaluate

### Making & Evaluating

#### Making

-Wheels could be made from wood, card, MDF, plastic, cotton reels, or foam-covered reels.

-Axles could be made from dowels or paper sticks.

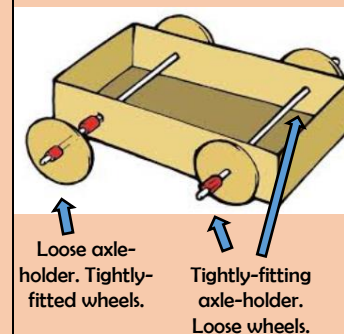

Free Axles - Fixed Wheels  
-The axles move with the wheels. Loose-fitting axle-holder, tightly fixed wheels.

Fixed Axles - Free Wheels  
-The axles will remain fixed to the chassis. The wheels move alone. Tight-fitting axle-holder, loose-fitting wheels.

#### Evaluating

-How well does your mechanism work? Does it move smoothly?

-Does it meet its purpose?

-Who would use your mechanism? What would they like about it?

-How did you prevent any unwanted friction?  
-How did this affect the mechanism?

-What else could you do to improve your mechanism?



### Health and Safety

-Remove any jewellery and tie back long hair.

-Wear an apron and roll up your sleeves.

-Walk safely and calmly around the classroom/workshop.

Keep your work area and floor area clear – keep your belongings well clear.

Follow the teacher's cutting instructions carefully.

Make sure that you are wearing the correct equipment for tasks.

If you need to move around with scissors, hold around the closed blades, facing down.

Report all spillages & clean up properly after yourself.